

TERMINAL BOXES



ELECTRICAL EQUIP.



Ex. COMPONENT

**TERMINAL BOXES:** Junction boxes RI series are normally used to contain terminal blocks and they are recommended for routing and interconnecting the wires at the intersection of the conduits. The wide range offered serve to meet the specific requirements indicated by the customer. They can be installed in areas classified as 1, 2, 21, 22 zones.

The construction characteristics of the RI series boxes make them suitable for ambient temperature: -50°C and +85°C.

**ELECTRICAL EQUIPMENT:** Electrical equipment boxes series ROI are normally used to contain electrical equipment and instrumentations that need to be visible such as ammeter, voltmeter, photocell, etc in classified area Zone 1 and Zone 21.

They are made in Stainless Steel AISI 316L with minimum thickness of 4mm so they have high resistance against mechanical damage and also high resistance against corrosion.

The maximum ambient temperature range certified is -50°C ÷ +85°C.

**Ex. COMPONENT:** Ex component boxes series RI, RO are empty enclosure supplied without any electrical equipment installed. They are not intended to be used alone and require additional certificate when incorporated into equipment or systems.

The wide range offered serve to meet the specific requirements indicated by the customer.

DISTRIBUITO DA- DISTRIBUTED BY

GCE SRL

MILANO - ITALY

[www.antideflagranti.com](http://www.antideflagranti.com)

comm@antideflagranti.com

**CABLE ENTRIES POSITION**

LATERAL ENTRIES					
CODE:	RI	RLI	RCI	RTI	RXI
	N° entries= 1	N° entries= 2		N° entries= 3	N° entries= 4
SCHEME:					

LATERAL AND BOTTOM ENTRIES					
CODE:	RBI	RMI	RDI	RWI	RXAI
	N° entries= 2	N° entries= 3		N° entries= 4	N° entries= 5
SCHEME:					

**EQUIPMENT IDENTIFICATION**

ORDER CODING				
Code	Cable entry dimension	Box dimension	Max internal dimension (with extension)	Model
R..I	1,2,3,4,5,6 20,25,32,40,50,63 See table below	6	120	MM (Terminal Box)
		6A	125	
		7	145	
		8	125 - 165	
		9	140 - 190	

Example: RTI26-120MM

CABLE ENTRY DIMENSION	
Code	Cable entry dimension
1	1/2" NPT
2	3/4" NPT
3	1" NPT
4	1.1/4" NPT
5	1.1/2" NPT
6	2" NPT
20	M20x1.5
25	M25x1.5
32	M32x1.5
40	M40x1.5
50	M50x1.5
63	M63x1.5



DISTRIBUITO DA- DISTRIBUTED BY

MILANO - ITALY

www.antideflagrante.com

**RI SERIES**

Junction boxes series RI are used to contain terminal blocks in classified area Zone 1 & Zone 21.



**Features**

**Material used:** stainless steel AISI 316L

**Operating temperature:** -50°C up to 85°C

**NPT thread:** from 1/2" to 2"

**ISO 262 thread:** from M20x1.5 5 to M63x1.5

**Degree of protection:** IP66

**Max rated voltage:** 690Vac/440Vdc

**Max rated current:** 109A

**Cross section:** 0,5 ÷ 35 mmq

**Nominal frequency:** 50/60Hz

**ATEX & IECEx Equipment Data**

<b>Gas</b>	Group II Zone 1	Ex db I Mb Ex db II C T(*) Gb
<b>Dust</b>	Group II Zone 21	Ex tb IIIC T(*) Db IP66
	Group I	I M2 Ex db IMb

**ATEX Certificate**

FTZU 14 ATEX 0088X

**IECEx Certificate**

IECEx FTZU 14.0021X

(\*) Temperature class: see table of max power dissipation on page 22

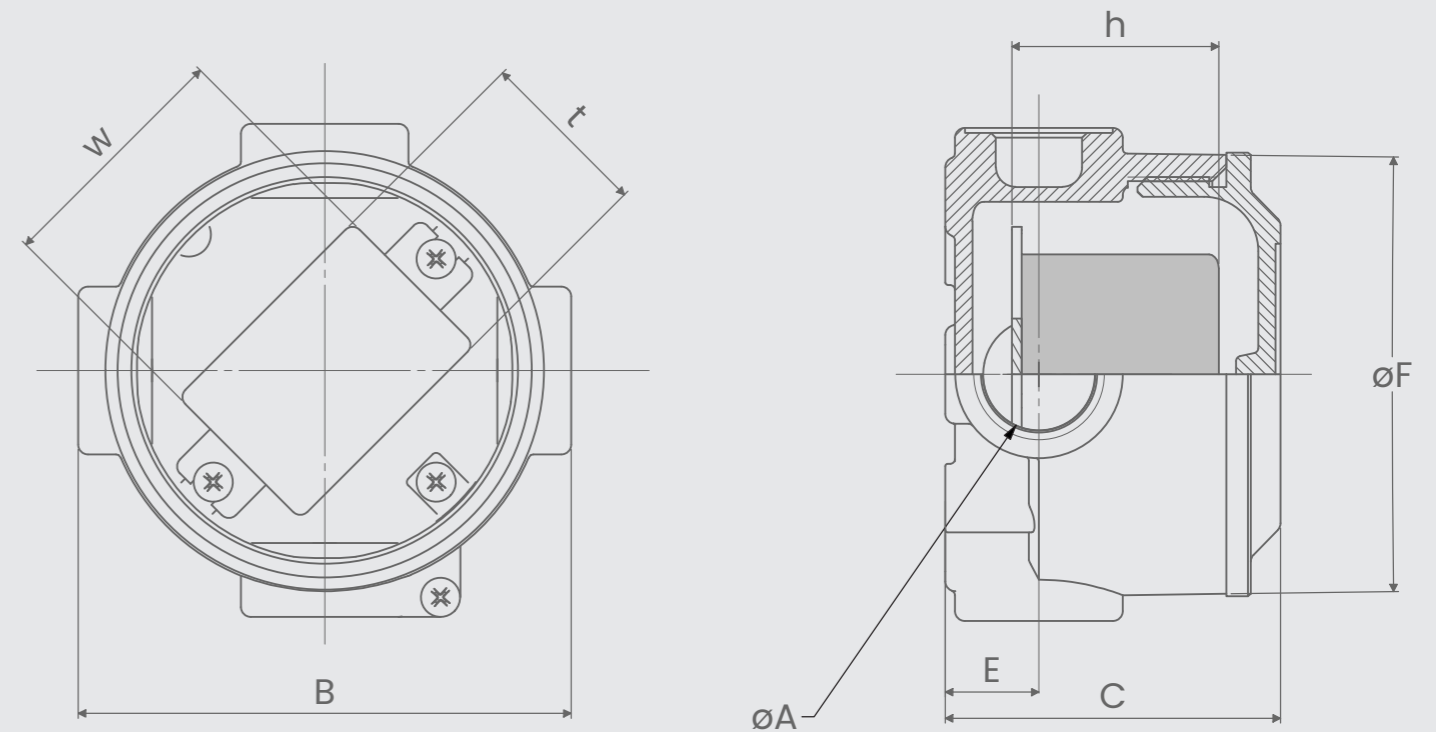

Box dimension	External dimensions [mm]				Max terminal blocks size [mm]			Max terminal blocks vol. [dm³]	Weight [Kg]
	B	C	E	ØF	h	w	t		
6	100	68	22,5	90	40	50	35	0,07	1,25
6A	100	73	22,5	90	45	50	35	0,078	1,3
7	126	82	24	112	50	65	45	0,146	2,2
8	145	99	27	131	65	70	60	0,273	3,5
9	161	115	27	146	80	85	65	0,414	4,4

ØA = See table at page 7



DISTRIBUITO DA- DISTRIBUTED BY

MILANO - ITALY

www.antideflagranti.com



RI Series - With bottom entry

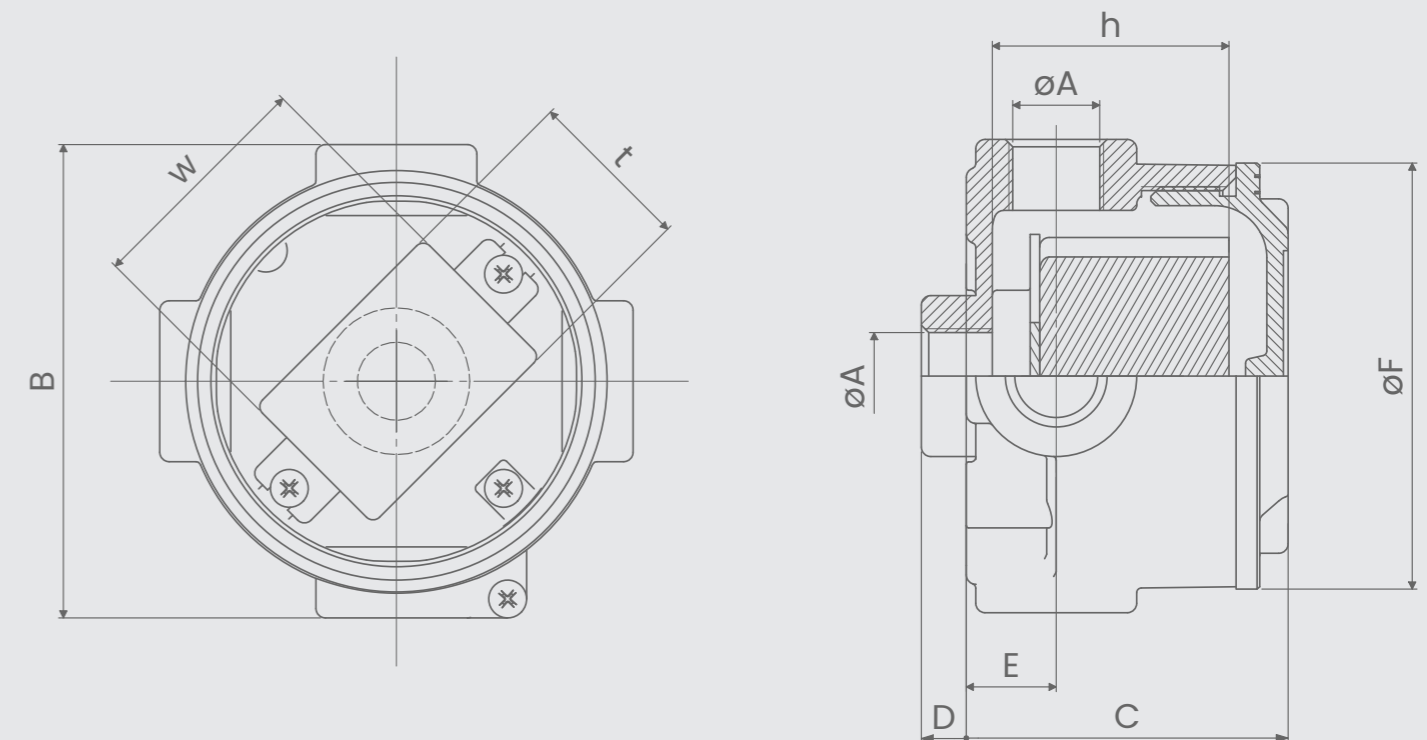
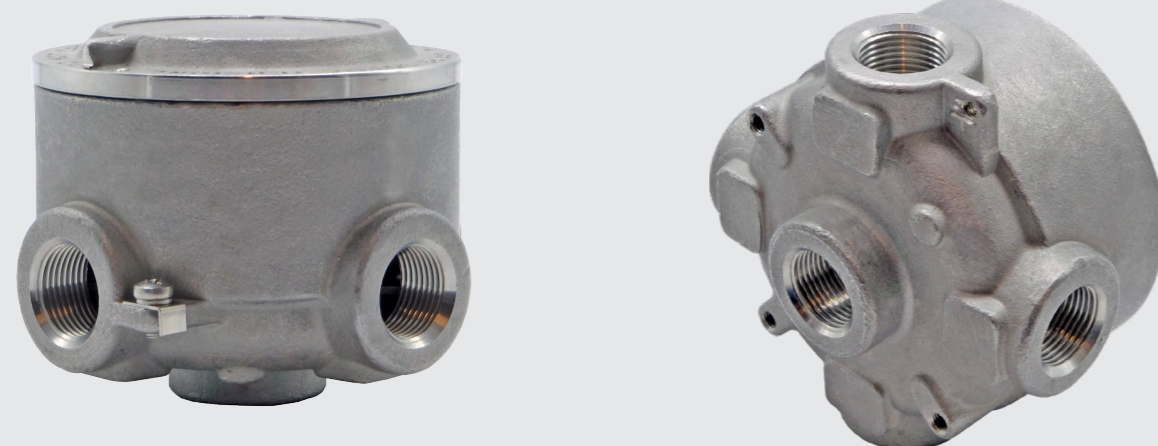

Features

Material used: stainless steel AISI 316L

Operating temperature: -50°C up to 85°C

NPT thread: from 1/2" to 2"

ISO 262 thread: from M20x1.5 5 to M63x1.5

Degree of protection: IP66

Max rated voltage: 690Vac/440Vdc

Max rated current: 109A

Cross section: 0,5 ÷ 35 mmq

Nominal frequency: 50/60Hz

ATEX & IECEx Equipment Data

<b>Gas</b>	Group II Zone 1	Ex db I Mb Ex db II C T(*) Gb
<b>Dust</b>	Group II Zone 21	Ex tb IIIC T(*) Db IP66
	Group I	I M2 Ex db IMb

ATEX Certificate

FTZU 14 ATEX 0088X

IECEx Certificate

IECEx FTZU 14.0021X

(\*) Temperature class: see table of max power dissipation on page 22

comm@antideflagranti.com

Box dimension	External dimensions [mm]					Max terminal blocks size [mm]			Max terminal blocks vol. [dm³]	Weight [Kg]
	B	C	D	E	ØF	h	w	t		
6	100	68	9,5	22,5	90	40	50	35	0,07	1,25
6A	100	73	9,5	22,5	90	45	50	35	0,078	1,3
7	126	82	11	24	112	50	65	45	0,146	2,2
8	145	99	9,5	27	131	65	70	60	0,273	3,5
9	161	115	9,5	27	146	80	85	65	0,414	4,4

ØA = See table at page 7



Fixing bracket

Fixing bracket

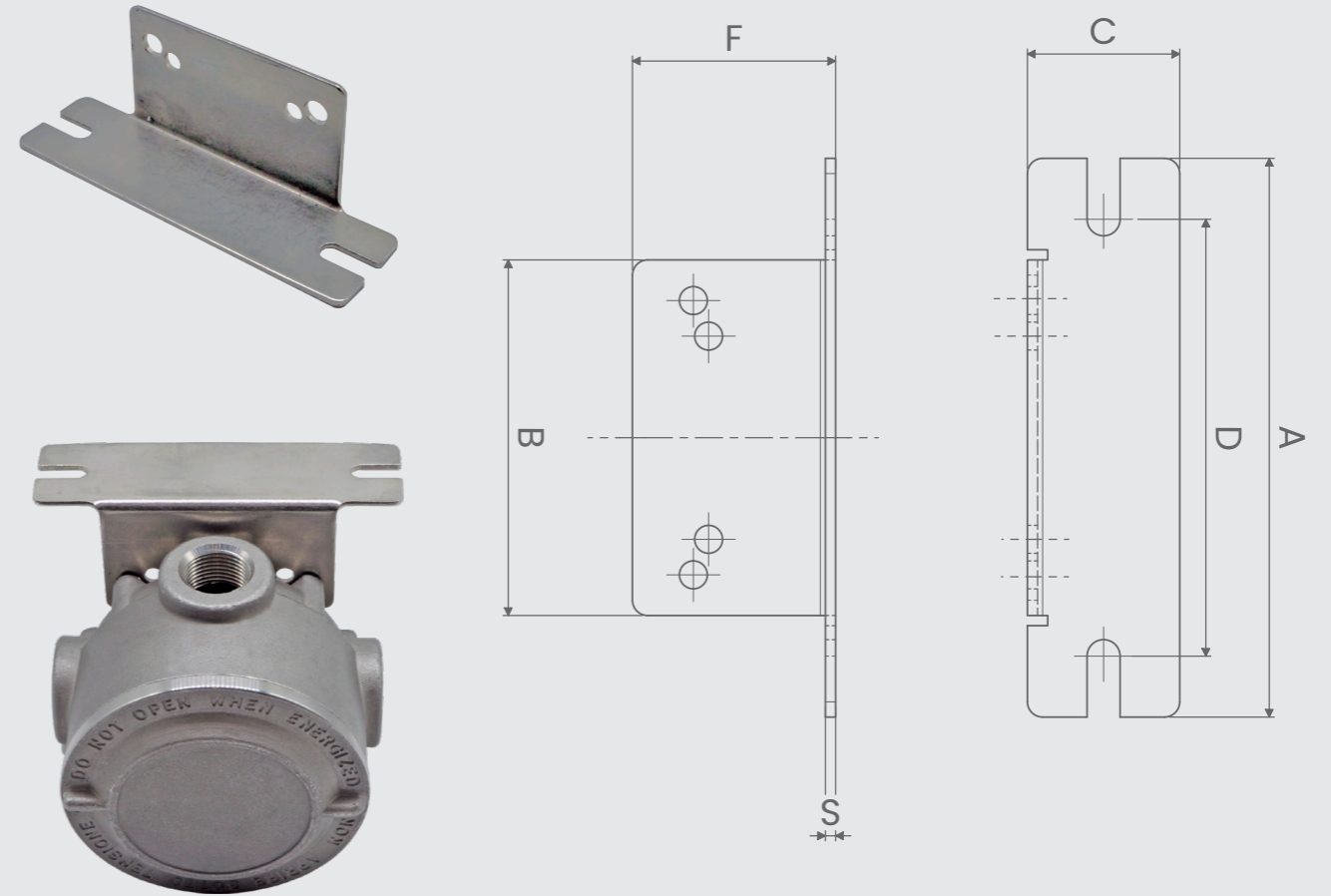
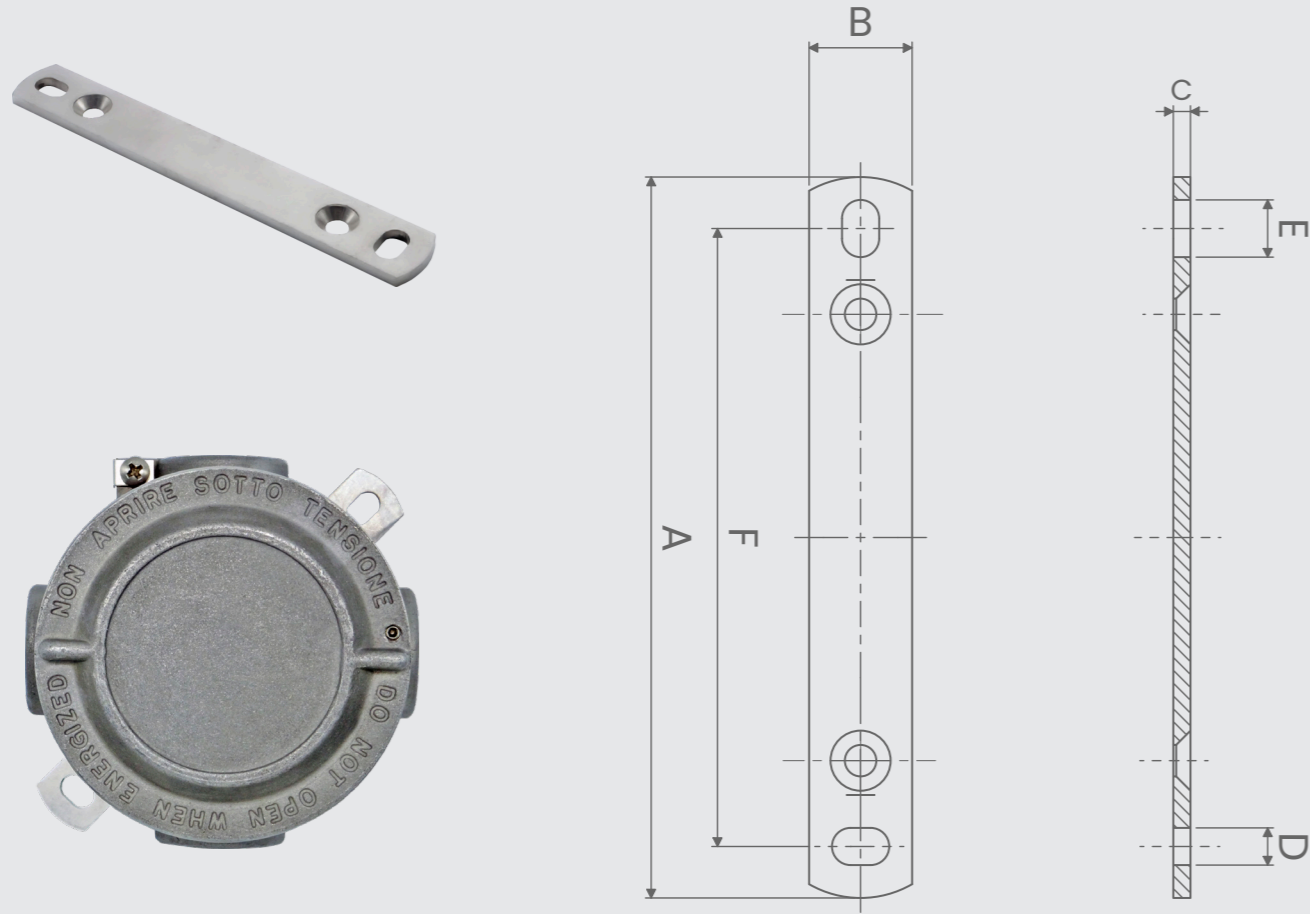

Code	A	B	C	D	E	F	Weight [kg]
<b>KF6S</b>	126	18	3	6,5	10	108	0,05
<b>KF7S</b>	142	18	3	6,5	10	124	0,057
<b>KF8S</b>	158	20	4	6,5	12	138	0,092
<b>KF9S</b>	174	20	4	6,5	12	154	0,1

Code	A	B	C	D	E	F	S	Weight [kg]
<b>KE46S</b>	110	70	30	86	6.5	40	2	0.09



MILANO - ITALY

www.antideflagranti.com  
comm@antideflagranti.com

Accessories

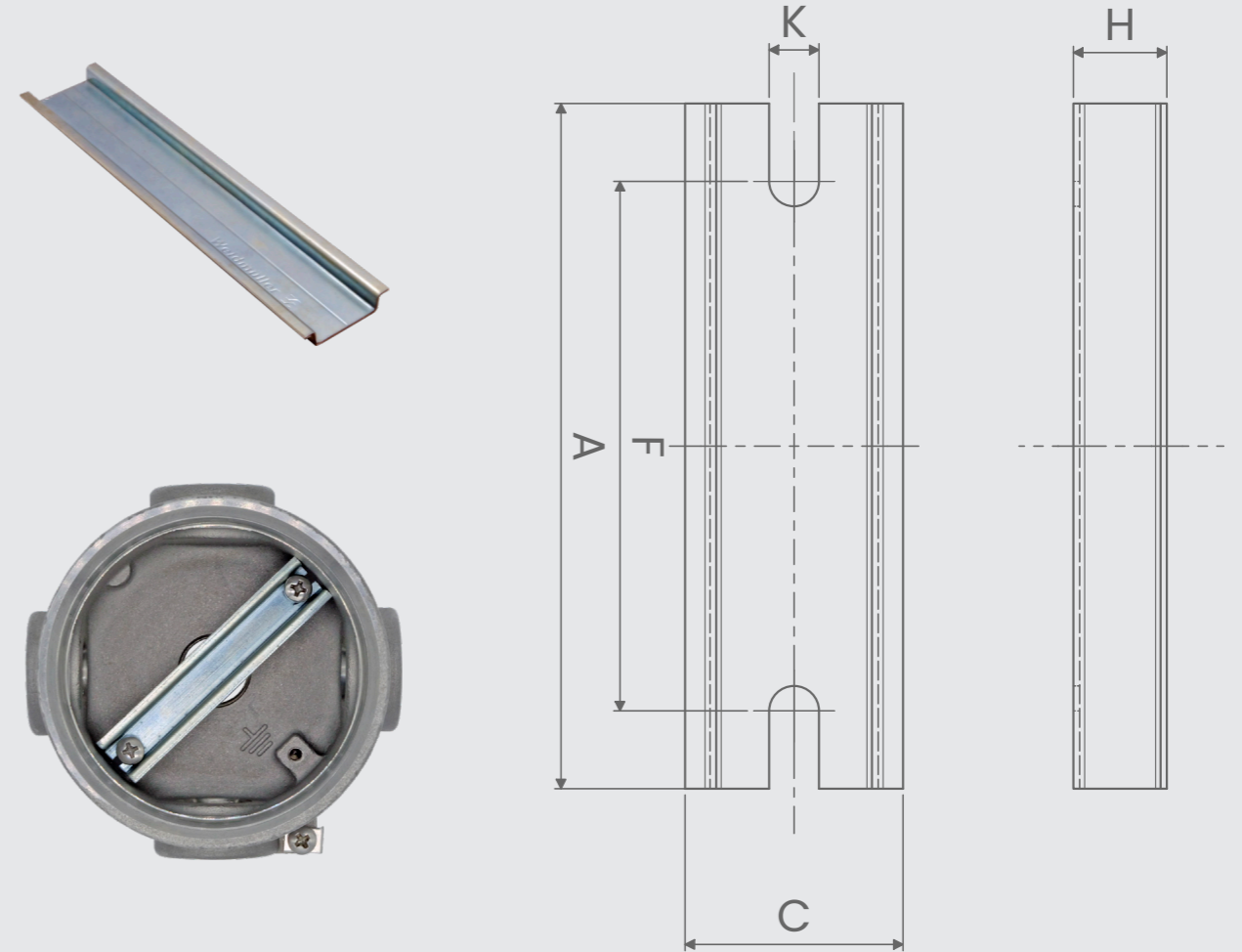
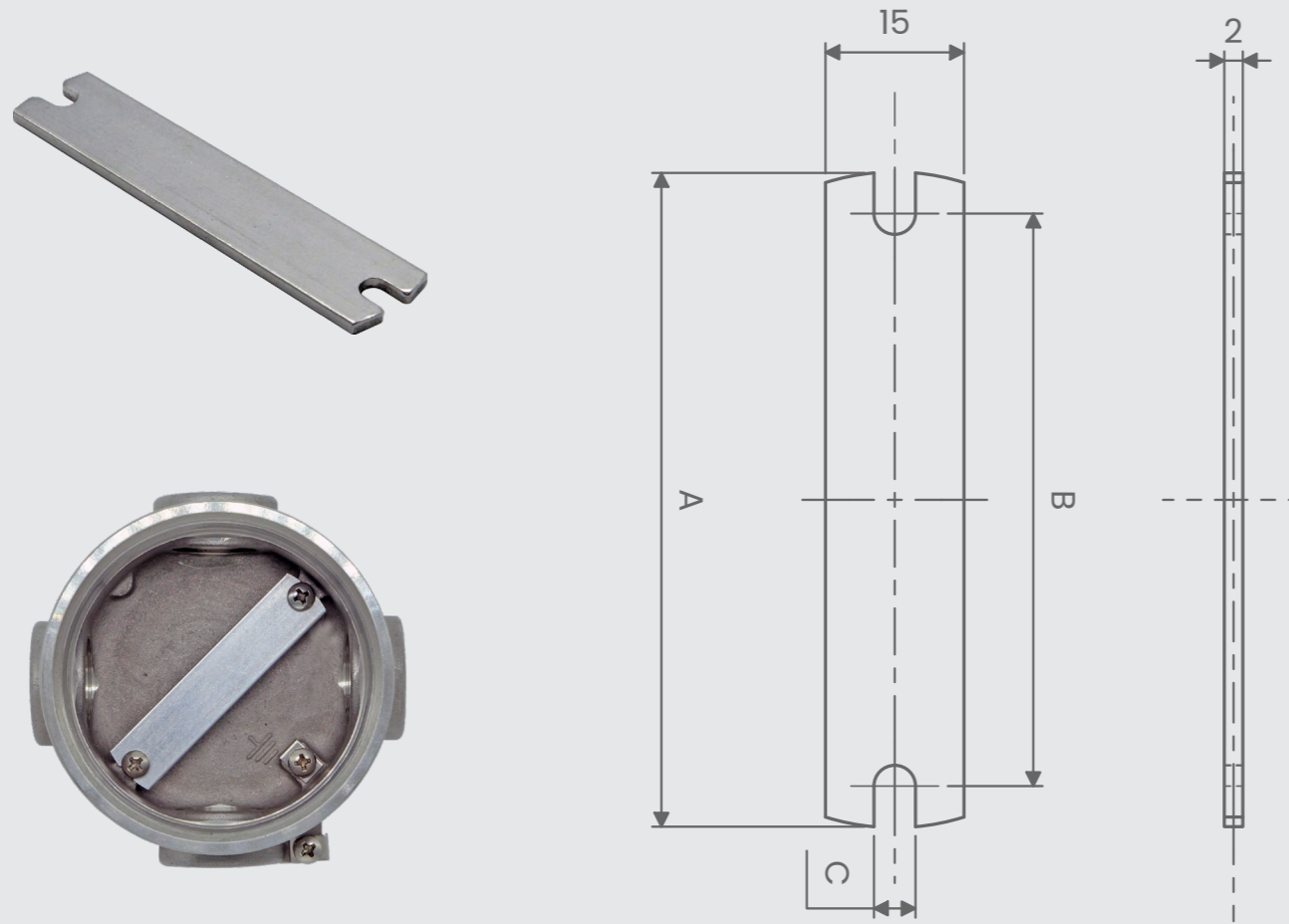

Code	A	B	C
KS6S	71	62	4.5
KS7S	90	76	4.5
KS8S	100	82	4.5
KS9S	110	98	4.5

Code	A	B	C	F	K
<b>FOR ENCLOSURE SIZE 6/6A</b>					
TS15	71	15	5,5	62	4,5
<b>FOR ENCLOSURE SIZE 7</b>					
TS15	71	15	5,5	62	4,5
<b>FOR ENCLOSURE SIZE 8</b>					
TS32	100	32	15	82	5,5
TS35	100	35	7,5/15	98	5,5
<b>FOR ENCLOSURE SIZE 9</b>					
TS32	110	32	15	82	5,5
TS35	110	35	7,5/15	98	5,5



MILANO - ITALY

www.antideflagrante.com

TABLE OF MAXIMUM DISSIPATED POWER

Enclosure size	Temp. Class	Max surface temp.	Cable / cable gland temp. for class I & class II equipment	O-ring material	Max ambient temp.	Max dissipated power
6 / 6A	T6	T 85° C	80° C	Silicone or EPDM	40° C	8 W
					50° C	5,5 W
					60° C	3 W
					70° C	1 W
	T5	T 100° C	95° C	Silicone or EPDM	40° C	11,5 W
					50° C	9 W
					60° C	6,5 W
					70° C	4,5 W
	T4	T 135° C	130° C	Silicone	85° C	1 W
					40° C	20,5 W
					50° C	18 W
					60° C	15 W
7	T6	T 85° C	80° C	Silicone or EPDM	70° C	12,5 W
					85° C	9 W
					40° C	10 W
					50° C	7 W
	T5	T 100° C	95° C	Silicone or EPDM	60° C	4 W
					70° C	1,5 W
					40° C	15 W
					50° C	11,5 W
	T4	T 135° C	130° C	Silicone	60° C	8,5 W
					70° C	5 W
					85° C	1,5 W
					40° C	30 W
T4	T 135° C	130° C	Silicone	50° C	26 W	
				60° C	21 W	
				70° C	17 W	
				85° C	11,5 W	

TABLE OF MAXIMUM DISSIPATED POWER

Enclosure size	Temp. Class	Max surface temp.	Cable / cable gland temp. for class I & class II equipment	O-ring material	Max ambient temp.	Max dissipated power
8	T6	T 85° C	80° C	Silicone or EPDM	40° C	11 W
					50° C	7,5 W
					60° C	4,5 W
					70° C	2 W
	T5	T 100° C	95° C	Silicone or EPDM	40° C	16 W
					50° C	12,5 W
					60° C	9 W
					70° C	6 W
	T4	T 135° C	130° C	Silicone	85° C	2 W
					40° C	31 W
					50° C	27 W
					60° C	22 W
9	T6	T 85° C	80° C	Silicone or EPDM	70° C	18 W
					85° C	12,5 W
					40° C	14 W
					50° C	10 W
	T5	T 100° C	95° C	Silicone or EPDM	60° C	6 W
					70° C	2,5 W
					40° C	21 W
					50° C	16 W
	T4	T 135° C	130° C	Silicone	60° C	12 W
					70° C	8 W
					85° C	2,5 W
					40° C	42 W
T4	T 135° C	130° C	Silicone	50° C	35 W	
				60° C	29 W	
				70° C	24 W	
				85° C	16 W	



DISTRIBUITO DA- DISTRIBUTED BY

MILANO - ITALY

www.antideflagranti.com

**CABLE ENTRIES POSITION**

LATERAL ENTRIES					
CODE:	ROI	ROLI	ROCI	ROTI	ROXI
	N° entries= 1	N° entries= 2		N° entries= 3	N° entries= 4
SCHEME:					

LATERAL AND BOTTOM ENTRIES					
CODE:	ROBI	ROMI	RODI	ROWI	ROXAI
	N° entries= 2	N° entries= 3		N° entries= 4	N° entries= 5
SCHEME:					



DISTRIBUITO DA- DISTRIBUTED BY

MILANO - ITALY

www.antideflagranti.com

**EQUIPMENT IDENTIFICATION**

ORDER CODING				
Code	Cable entry dimension	Box dimension	Max internal dimension (with extension)	Model
R..I	1,2,3,4,5,6	6	120	See table at page 32
	20,25,32,40,50,63	6A	125	
	See table below	7	145	
		8	125 - 165	
		9	140 - 190	

CABLE ENTRY DIMENSION	
Code	Cable entry dimension
1	1/2" NPT
2	3/4" NPT
3	1" NPT
4	1.1/4" NPT
5	1.1/2" NPT
6	2" NPT
20	M20x1.5
25	M25x1.5
32	M32x1.5
40	M40x1.5
50	M50x1.5
63	M63x1.5

Example: ROTI26-120MM



**RI - ROI SERIES**

Electrical equipment boxes serieis ROI are normally used to contain electrical equipment and instrumentation that need to be visible such as ammeter, voltmeter, photocell, etc in classified area Zone 1 and Zone 21.

[comm@antideflagranti.com](mailto:comm@antideflagranti.com)

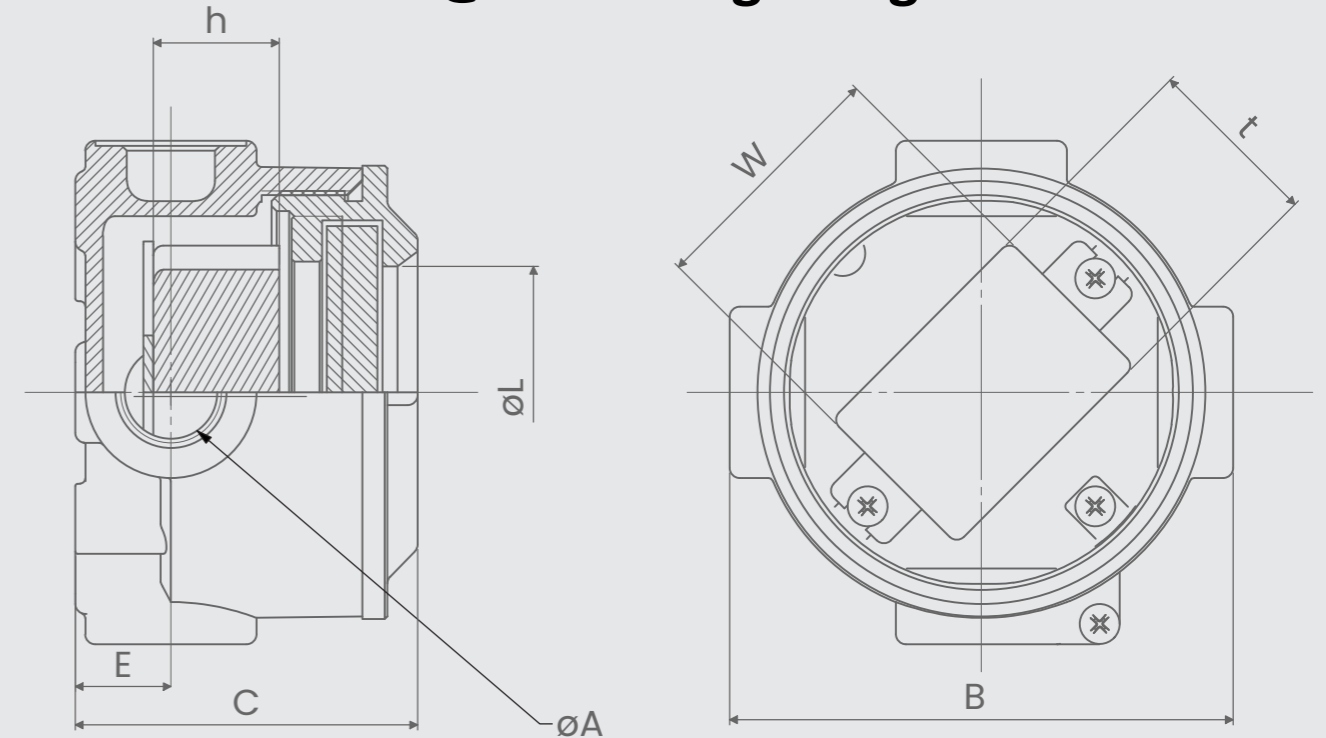

**Features**

- Material used:** stainless steel AISI 316L
- Operating temperature:** -50°C up to 85°C
- NPT thread:** from 1/2" to 2"
- ISO 262 thread:** from M20x1.5 5 to M63x1.5
- Degree of protection:** IP66

- Max rated voltage:** 690Vac/440Vdc
- Max rated current:** 109A
- Cross section:** 0,5 ÷ 35 mmq
- Nominal frequency:** 50/60Hz

**ATEX & IECEx Equipment Data**

<b>Gas</b>	Group II Zone 1	Ex db I Mb Ex db II C T(*) Gb
<b>Dust</b>	Group II Zone 21	Ex tb IIIC T(*) Db IP66
	Group I	I M2 Ex db IMb

**ATEX Certificate**

FTZU 14 ATEX 0088X

**IECEx Certificate**

IECEx FTZU 14.0021X

(\*) Temperature class: see table of max power dissipation on page 38

Box dimension	External dimensions [mm]				Max equipments size [mm]		Max equipment [mm]	Weight [Kg]		
	With window	E	ØF	ØL	h	w				
6	100	68	22,5	90	50	30	50	35	0,07	1,25
6A	100	73	22,5	90	50	35	50	35	0,078	1,3
7	126	82	24	112	70	40	65	45	0,146	2,2
8	145	99	27	131	85	55	70	60	0,273	3,5
9	161	115	27	146	100	65	85	65	0,414	4,4

ØA = See table at page 25

[comm@antideflagranti.com](mailto:comm@antideflagranti.com)



DISTRIBUITO DA- DISTRIBUTED BY

**GCE SRL**



MILANO - ITALY

[www.antideflagranti.com](http://www.antideflagranti.com)

**RI - ROI SERIES - With bottom entry**

Electrical equipment boxes serieis ROI are normally used to contain electrical equipment and instrumentation that need to be visible such as ammeter, voltmeter, photocell, etc in classified area Zone 1 and Zone 21.



**Features**

- Material used:** stainless steel AISI 316L
- Operating temperature:** -50°C up to 85°C
- NPT thread:** from 1/2" to 2"
- ISO 262 thread:** from M20x1.5 5 to M63x1.5
- Degree of protection:** IP66

- Max rated voltage:** 690Vac/440Vdc
- Max rated current:** 109A
- Cross section:** 0,5 ÷ 35 mmq
- Nominal frequency:** 50/60Hz

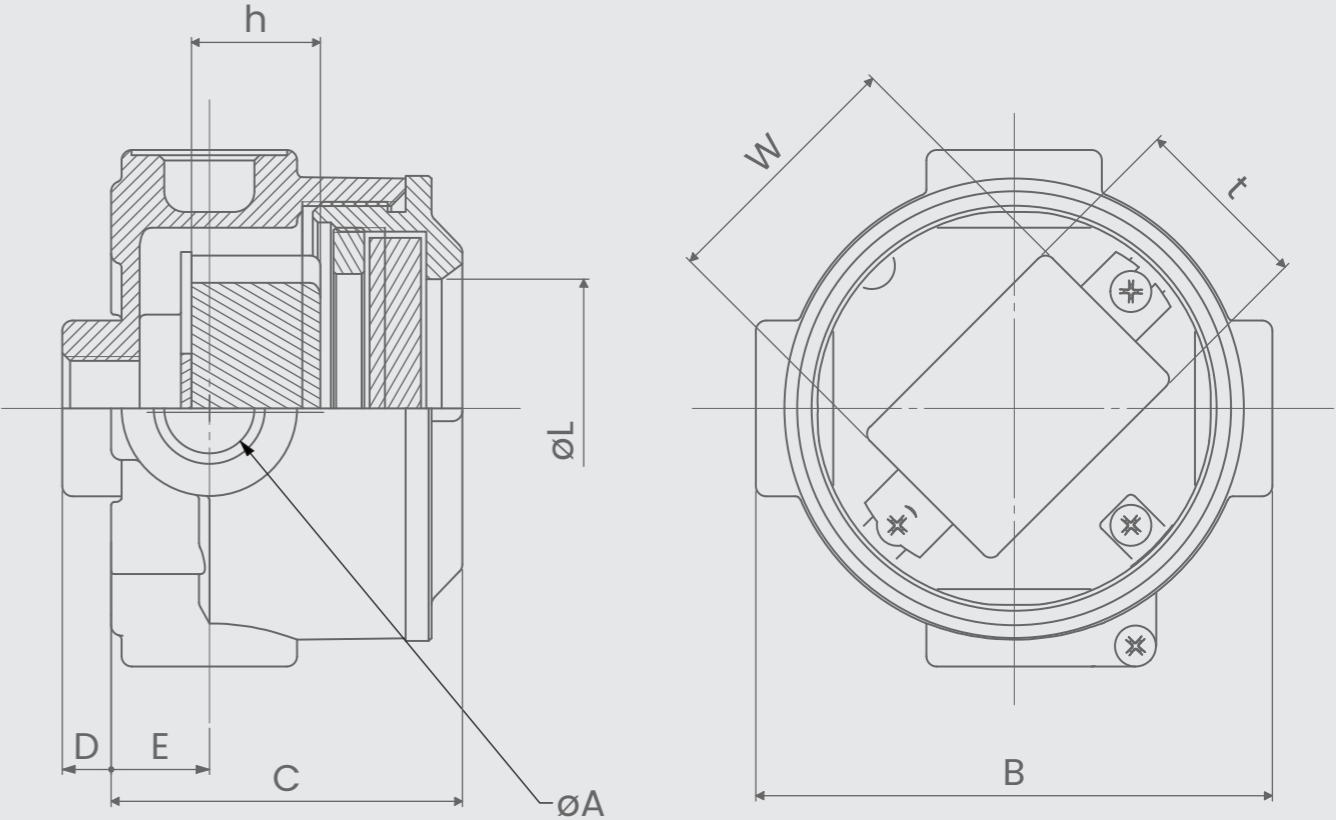

**ATEX & IECEx Equipment Data**

<b>Gas</b>	Group II Zone 1	Ex db I Mb Ex db II C T(*) Gb
<b>Dust</b>	Group II Zone 21	Ex tb IIIC T(*) Db IP66
	Group I	I M2 Ex db IMb

ATEX Certificate	IECEx Certificate
FTZU 14 ATEX 0088X	IECEx FTZU 14.0021X

(\*) Temperature class: see table of max power dissipation on page 38

Box dimension	External dimensions [mm]						Max equipments size [mm]		Max equipment [mm]	Weight [Kg]	
	With window	D	E	ØF	ØL	h	w	Without window			
6	100	68	9,5	22,5	90	50	30	50	35	0,07	1,25
6A	100	73	9,5	22,5	90	50	35	50	35	0,078	1,3
7	126	82	11	24	112	70	40	65	45	0,146	2,2
8	145	99	9,5	27	131	85	55	70	60	0,273	3,5
9	161	115	9,5	27	146	100	65	85	65	0,414	4,4

ØA = See table at page 25

[comm@antideflagranti-gce.com](mailto:comm@antideflagranti-gce.com)



MILANO - ITALY

[www.antideflagranti-gce.com](http://www.antideflagranti-gce.com)

EXTENSION FOR ENCLOSURES

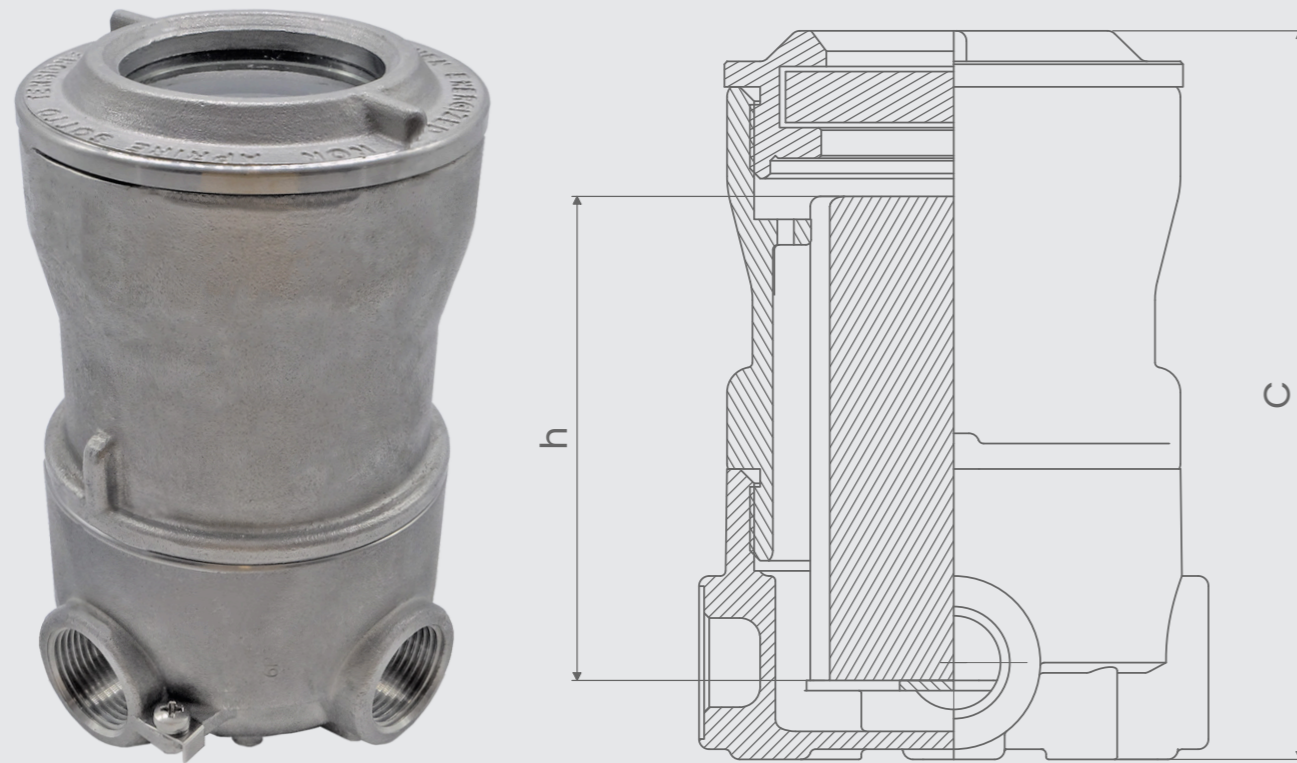

MAXIMUM ELECTRICAL VALUES ADMITTED

- Maximum Tension: 660 Vac / 440 Vdc
- Maximum Current: 109A
- Frequency: 50 / 60 Hz
- Cross section: 0,5 ÷ 35 mm<sup>2</sup>

NOTES

- The electrical equipments must have such dimensions that guarantee, in every trasversal section, at least the 40% of free surface.
- Max power dissipation must be in accordance with the value written at pag.
- No batteries are allowed inside the enclosure.
- Electrical equipment contained in the enclosure shall not be intrinsically safe and it shall not include capillaries or other non electric connections.
- In case of presence of capacitors, when the voltage goes off they must be discharged within their own circuit in less than one second.
- When the device is used for Group I (Mines), insulating material subject to electrical stresses capable of causing arc in the air and which result from rated currents of more than 16A shall have a comparative tracking index equal to or greater than CTI 400 M, according to IEC 60112.

Code with extension	Box Dimension	External Dim. [mm]	Max equip. size [mm]	Max equip. Vol. [dm <sup>3</sup> ]	Weight [Kg]
		c	h		
R.. - 110	6	143	95	0,15	2,1
R.. - 115	6A	148	100	0,15	2,2
R.. - 135	7	172	120	0,3	3,5
R.. - 155	8	189	130	0,55	5,1
R.. - 175	9	215	150	0,8	6,8

DISTRIBUITO DA- DISTRIBUTED BY

**GCE SRL**

MILANO - ITALY

[www.antideflagranti.com](http://www.antideflagranti.com)



comm@antideflagrante.com

EXTENSION FOR ENCLOSURES



DISTRIBUITO DA- DISTRIBUTED BY

MILANO - ITALY

www.antideflagrante.com

BRACKET FOR DIN 43700 - KH

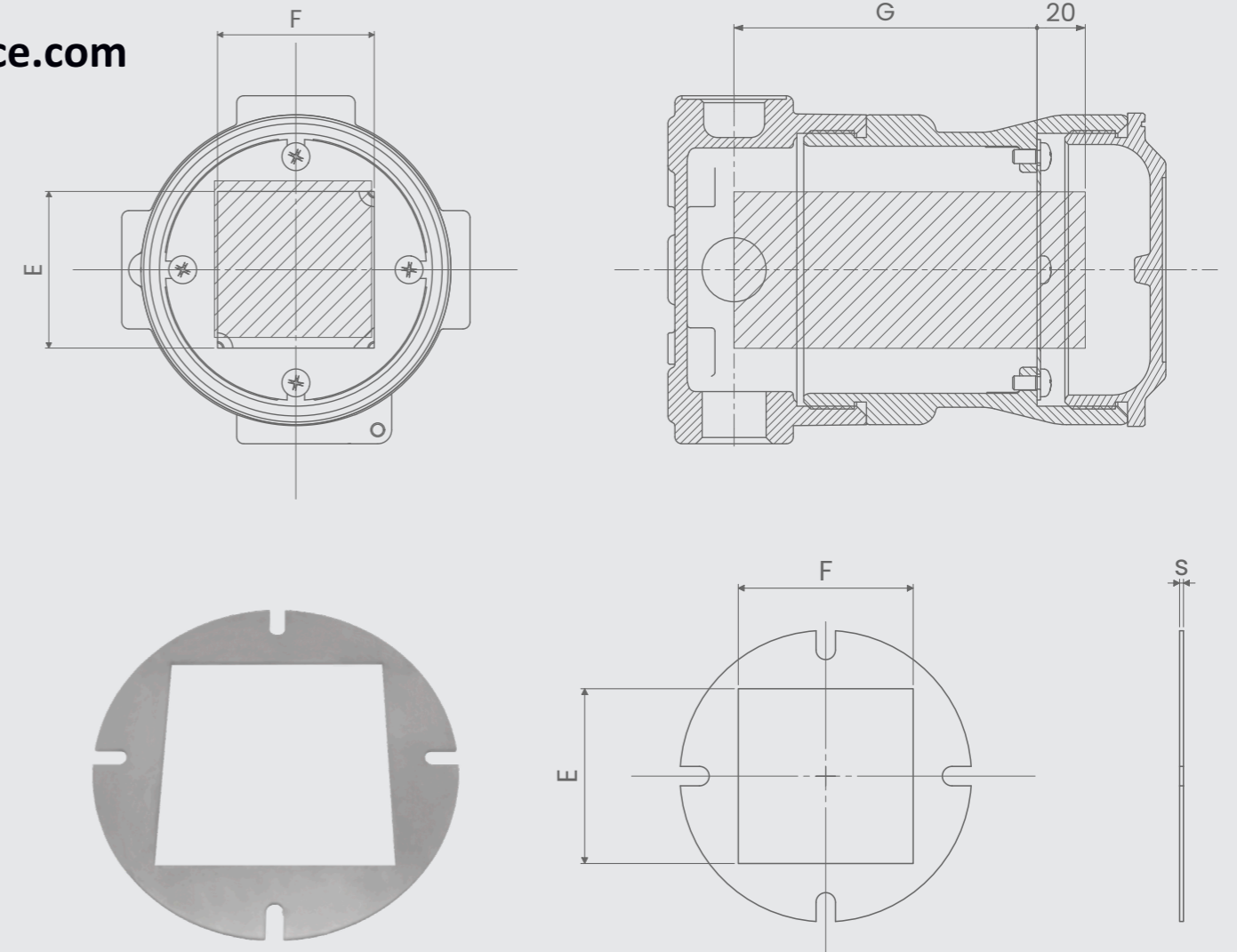
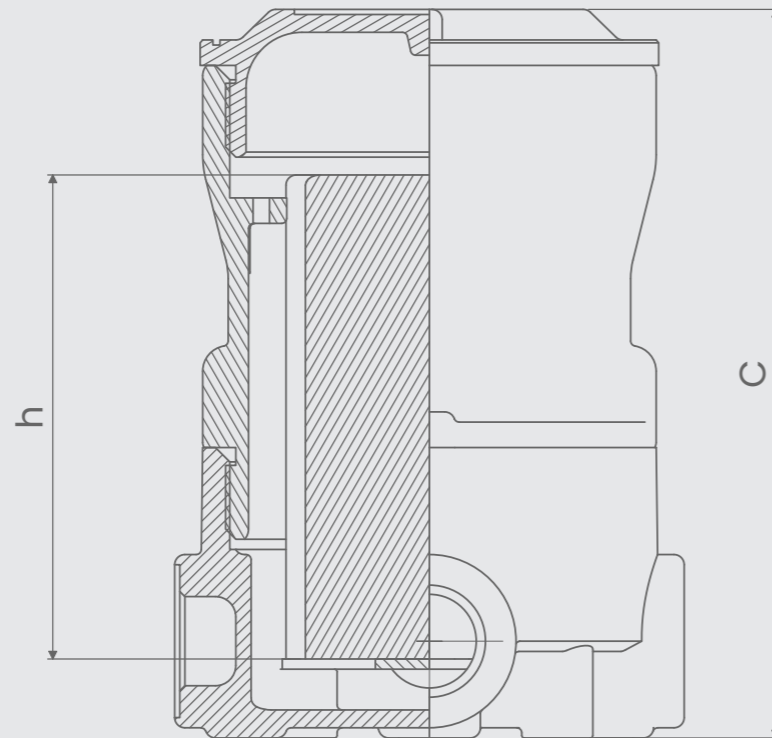

Code with extension	Box Dimension	External Dim. [mm]	Max equip. size [mm]	Max equip. Vol. [dm <sup>3</sup> ]	Weight [Kg]
		c	h		
R.. - 110	6	143	105	0,18	2,1
R.. - 115	6A	148	110	0,18	2,2
R.. - 135	7	172	130	0,35	3,5
R.. - 155	8	189	140	0,58	5,1
R.. - 175	9	215	160	0,88	6,8

Dimension Box	DIN 43700	KH	E	F	s	G
6 - 95 ÷ 120	36 x 36	KH6-3636	33	33	1,5	55 ÷ 85
6 - 95 ÷ 120	48 x 24	KH6-4824	45	22,2	1,5	55 ÷ 85
6A - 100 ÷ 125	36 x 36	KH6-3636	33	33	1,5	60 ÷ 90
6A - 100 ÷ 125	48 x 24	KH6-4824	45	22,2	1,5	60 ÷ 90
7 - 105 ÷ 145	48 x 48	KH7-4848	45	45	1,5	60 ÷ 110
8 - 125 ÷ 165	72 x 36	KH8-7236	68	33	1,5	70 ÷ 120
8 - 140 ÷ 190	72 x 72	KH8-7272	68	68	1,5	80 ÷ 140
9 - 140 ÷ 190	96 x 24	KH9-9624	92	22,2	1,5	80 ÷ 140
9 - 140 ÷ 190	96 x 48	KH9-9648	92	45	1,5	80 ÷ 140

## TYPE OF SUITABLE EQUIPMENTS

SUITABLE EQUIPMENTS	
Code	Model
A	Ammeter
ADC	Analogic to digital signal converter
CI	Phase insulation controller
CO	Hours Counter
CP	Pulse counter
DAC	Digital to analogic signal converter
DE	LCD indicator panel
F	Frequencymeter
FM	Single phase power factor meter
FT	Three phase power factor meter
IC	Twilight switch
ICA	Load cell indicator
IO	Clock switch
LVM	Single phase overload voltage
LVT	Three phase overload voltage
MI	Phase insulation meter
MM	Multifunction meter
O	Digital electronic clock
PC	Cam programmer
PE	Electronic programmer
PF	Fuse holder
RC	Control relay
RP	Stop relay
RT	Time dealy relay
SCM	Control, measuring and regulation electronic board
SL	Light sensor
TL	Camera
TP	Programmable timer switch
TR	Thermoregulator
W	Wattmeter / Voltmeter



DISTRIBUITO DA- DISTRIBUTED BY

**GCE SRL**

MILANO - ITALY

[www.antideflagranti.com](http://www.antideflagranti.com)



Fixing bracket

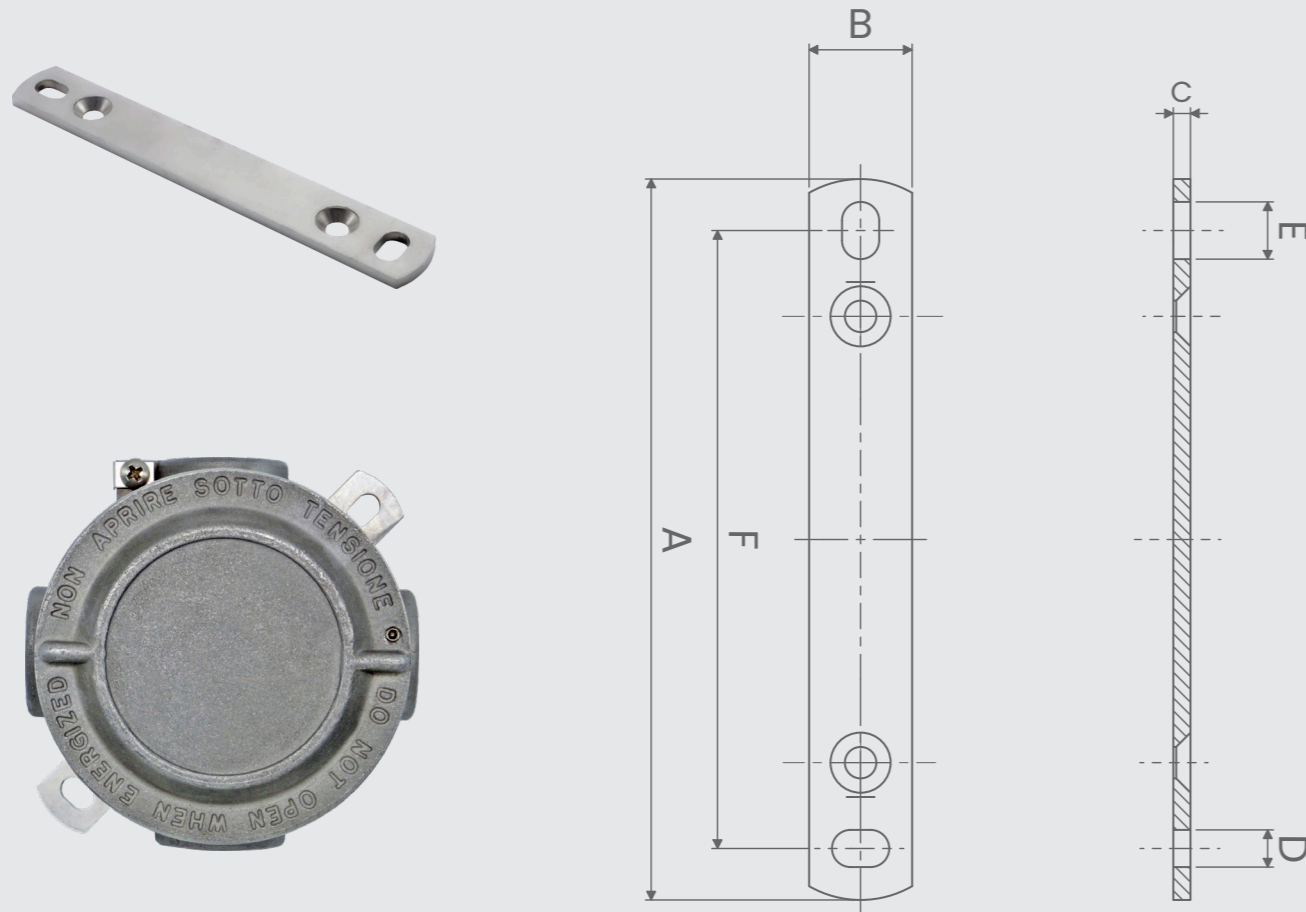

Code	A	B	C	D	E	F	Weight [kg]
KF6S	126	18	3	6,5	10	108	0,05
KF7S	142	18	3	6,5	10	124	0,057
KF8S	158	20	4	6,5	12	138	0,092
KF9S	174	20	4	6,5	12	154	0,1

Fixing bracket

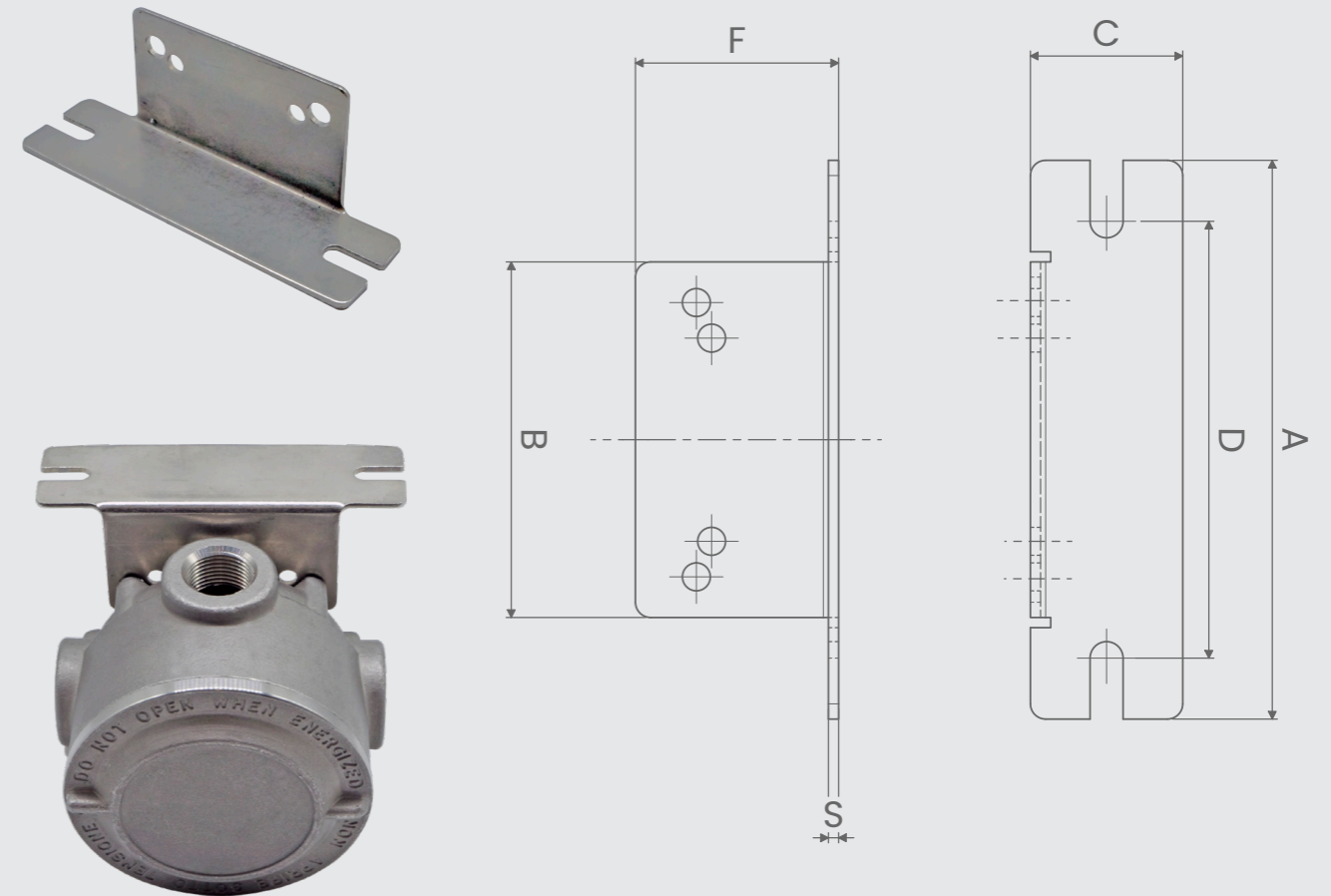

Code	A	B	C	D	E	F	S	Weight [kg]
KE46S	110	70	30	86	6.5	40	2	0.09



DISTRIBUITO DA- DISTRIBUTED BY

MILANO - ITALY

www.antideflagranti.com

Accessories

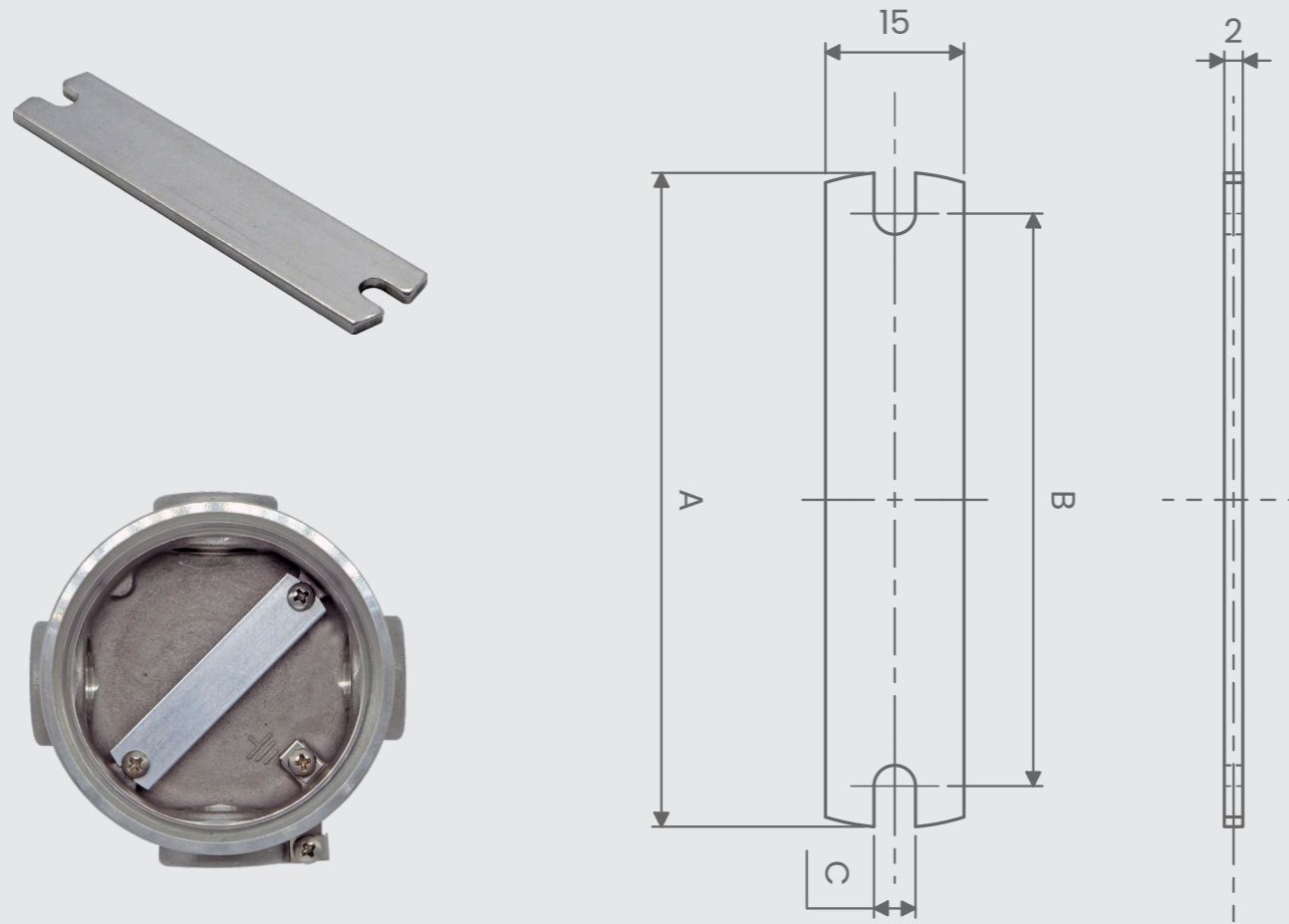

Code	A	B	C
KS6S	71	62	4.5
KS7S	90	76	4.5
KS8S	100	82	4.5
KS9S	110	98	4.5



DISTRIBUITO DA- DISTRIBUTED BY

MILANO - ITALY

www.antideflagranti.com

comm@antideflagranti.com

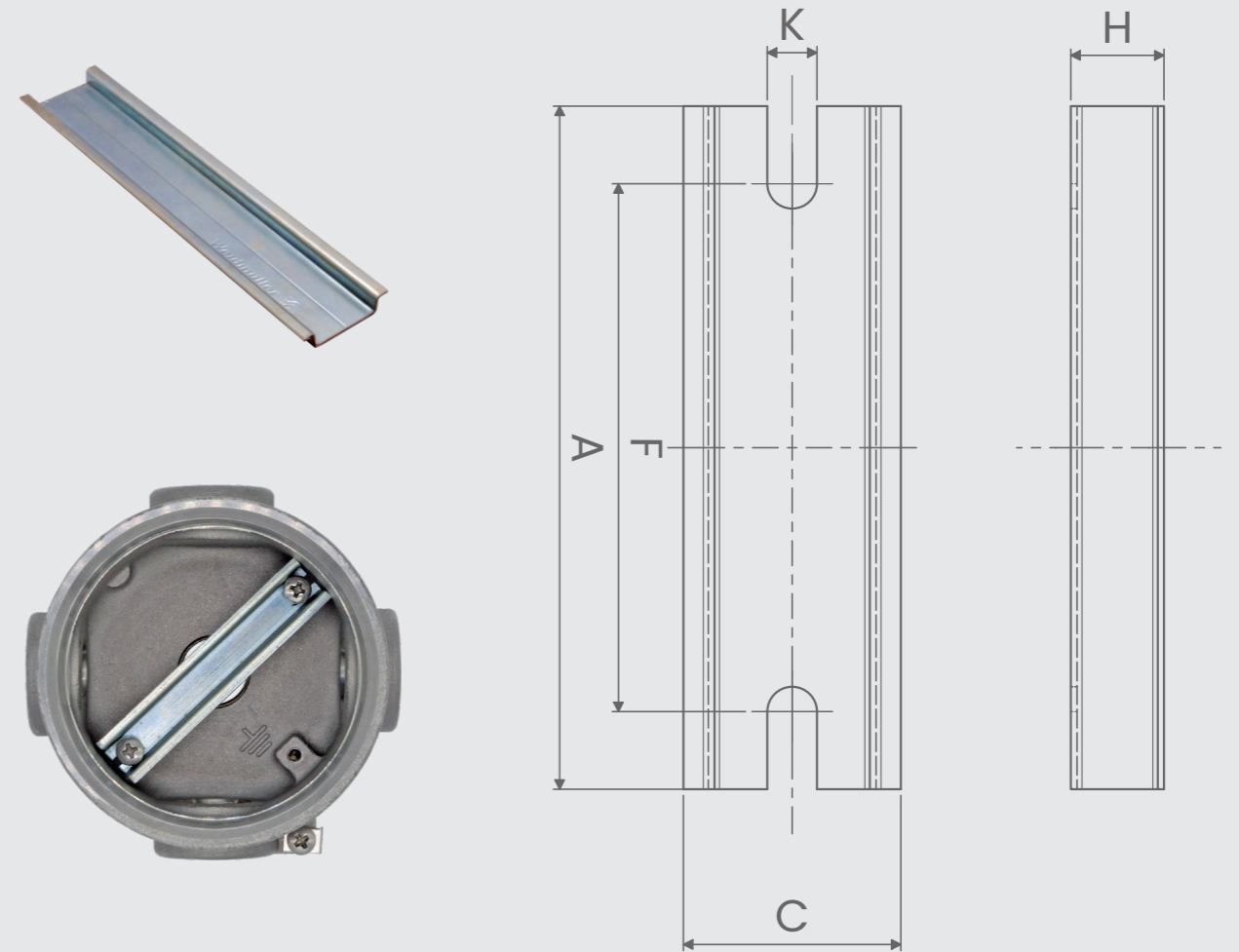

Code	A	B	C	F	K
<b>FOR ENCLOSURE SIZE 6/6A</b>					
TS15	71	15	5,5	62	4,5
<b>FOR ENCLOSURE SIZE 7</b>					
TS15	71	15	5,5	62	4,5
<b>FOR ENCLOSURE SIZE 8</b>					
TS32	100	32	15	82	5,5
TS35	100	35	7,5/15	98	5,5
<b>FOR ENCLOSURE SIZE 9</b>					
TS32	110	32	15	82	5,5
TS35	110	35	7,5/15	98	5,5

TABLE OF MAXIMUM DISSIPATED POWER

Enclosure size	Temp. Class	Max surface temp.	Cable / cable gland temp. for class I & class II equipment	O-ring material	Max ambient temp.	Max dissipated power
6 / 6A	T6	T 85° C	80° C	Silicone or EPDM	40° C	8 W
					50° C	5,5 W
					60° C	3 W
					70° C	1 W
	T5	T 100° C	95° C	Silicone or EPDM	40° C	11,5 W
					50° C	9 W
					60° C	6,5 W
					70° C	4,5 W
	T4	T 135° C	130° C	Silicone	85° C	1 W
					40° C	20,5 W
					50° C	18 W
					60° C	15 W
7	T6	T 85° C	80° C	Silicone or EPDM	70° C	12,5 W
					85° C	9 W
					40° C	10 W
					50° C	7 W
	T5	T 100° C	95° C	Silicone or EPDM	60° C	4 W
					70° C	1,5 W
					40° C	15 W
					50° C	11,5 W
	T4	T 135° C	130° C	Silicone	60° C	8,5 W
					70° C	5 W
					85° C	1,5 W
					40° C	30 W
T4	T 135° C	130° C	Silicone	50° C	26 W	
				60° C	21 W	
				70° C	17 W	
				85° C	11,5 W	

TABLE OF MAXIMUM DISSIPATED POWER

Enclosure size	Temp. Class	Max surface temp.	Cable / cable gland temp. for class I & class II equipment	O-ring material	Max ambient temp.	Max dissipated power
8	T6	T 85° C	80° C	Silicone or EPDM	40° C	11 W
					50° C	7,5 W
					60° C	4,5 W
					70° C	2 W
	T5	T 100° C	95° C	Silicone or EPDM	40° C	16 W
					50° C	12,5 W
					60° C	9 W
					70° C	6 W
	T4	T 135° C	130° C	Silicone	85° C	2 W
					40° C	31 W
					50° C	27 W
					60° C	22 W
9	T6	T 85° C	80° C	Silicone or EPDM	70° C	18 W
					85° C	12,5 W
					40° C	14 W
					50° C	10 W
	T5	T 100° C	95° C	Silicone or EPDM	60° C	6 W
					70° C	2,5 W
					40° C	21 W
					50° C	16 W
	T4	T 135° C	130° C	Silicone	60° C	12 W
					70° C	8 W
					85° C	2,5 W
					40° C	42 W
T4	T 135° C	130° C	Silicone	50° C	35 W	
				60° C	29 W	
				70° C	24 W	
				85° C	16 W	



DISTRIBUITO DA- DISTRIBUTED BY

MILANO - ITALY

www.antideflagrante.com

**CABLE ENTRIES POSITION**

LATERAL ENTRIES					
CODE:	RI	RLI	RCI	RTI	RXI
	N° entries= 1	N° entries= 2		N° entries= 3	N° entries= 4
SCHEME:					

LATERAL AND BOTTOM ENTRIES					
CODE:	RBI	RMI	RDI	RWI	RXAI
	N° entries= 2	N° entries= 3		N° entries= 4	N° entries= 5
SCHEME:					

**EQUIPMENT IDENTIFICATION**

ORDER CODING				
Code	Cable entry dimension	Box dimension	Max internal dimension (with extension)	Model
R..I	1,2,3,4,5,6 20,25,32,40,50,63 See table below	6	120	See table at page 30
		6A	125	
		7	145	
		8	125 - 165	
		9	140 - 190	

CABLE ENTRY DIMENSION	
Code	Cable entry dimension
1	1/2" NPT
2	3/4" NPT
3	1" NPT
4	1.1/4" NPT
5	1.1/2" NPT
6	2" NPT
20	M20x1.5
25	M25x1.5
32	M32x1.5
40	M40x1.5
50	M50x1.5
63	M63x1.5



DISTRIBUITO DA- DISTRIBUTED BY

**GCE SRL**

MILANO - ITALY

www.antideflagranti.com

Example: ROTI26-120MM

comm@antideflagranti.com

**RI SERIES - EX COMPONENT**

Ex component boxes series RI, RO are empty enclosure supplied without any electrical equipment installed. They are not intended to be used alone and require additional certificate when incorporated into equipment or systems.

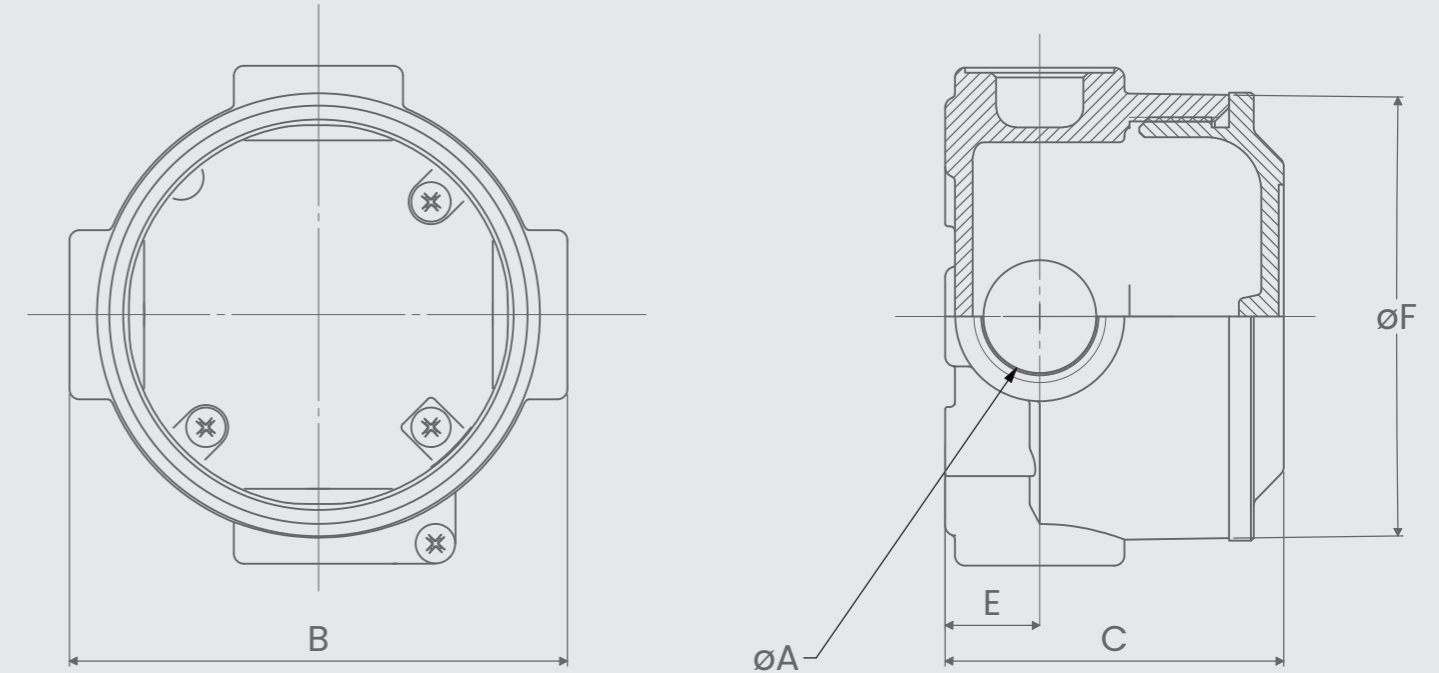
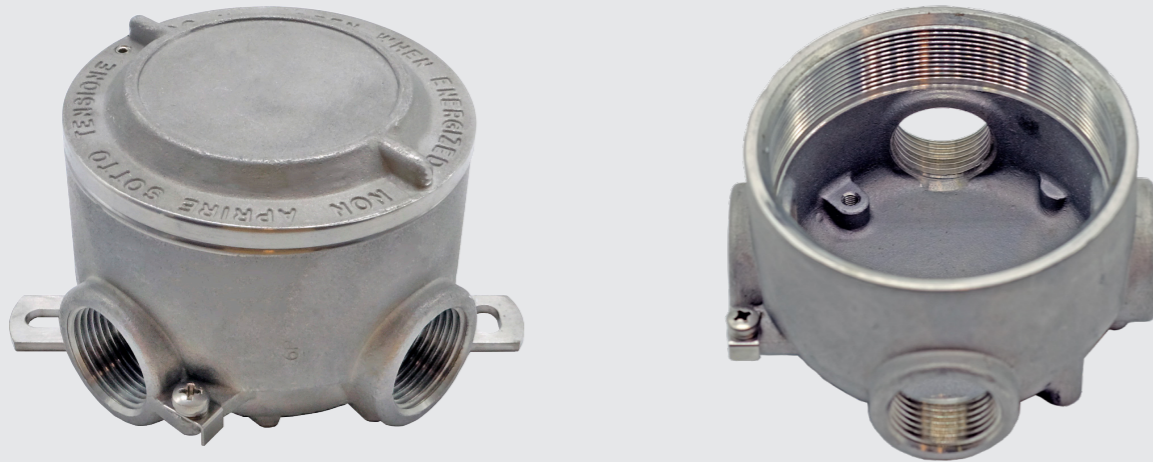

**Features**

**Material used:** stainless steel AISI 316L

**Operating temperature:** -50°C up to 85°C

**NPT thread:** from 1/2" to 2"

**ISO 262 thread:** from M20x1.5 5 to M63x1.5

**Degree of protection:** IP66

**Max rated voltage:** 690Vac/440Vdc

**Max rated current:** 109A

**Cross section:** 0,5 ÷ 35 mmq

**Nominal frequency:** 50/60Hz

**ATEX & IECEx Equipment Data**

<b>Gas</b>	Group II Zone 1	Ex db I Mb Ex db II C T(*) Gb
<b>Dust</b>	Group II Zone 21	Ex tb IIIC T(*) Db IP66
	Group I	I M2 Ex db IMb

**ATEX Certificate**

FTZU 13 ATEX 0201U

**IECEx Certificate**

IECEx FTZU 14.0055U

Box dimension	External dimensions [mm]				Weight [Kg]
	B	C	E	ØF	
6	100	68	22,5	90	1,25
6A	100	73	22,5	90	1,3
7	126	82	24	112	2,2
8	145	99	27	131	3,5
9	161	115	27	146	4,4

ØA = See table at page 41



DISTRIBUITO DA- DISTRIBUTED BY

MILANO - ITALY

www.antideflagranti.com